

Etherwave | Pro Theremin

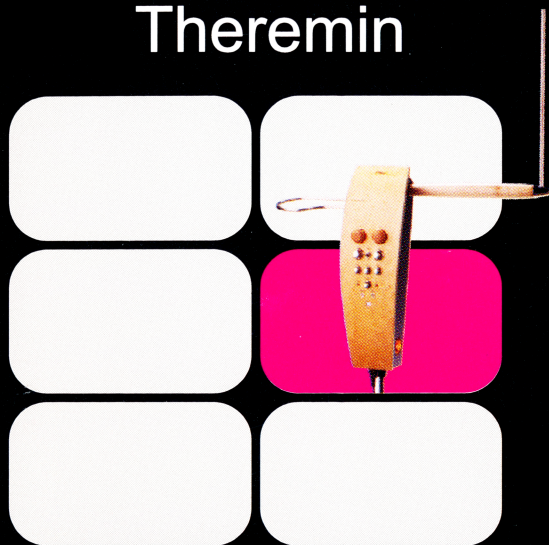

manual

IMPORTANT SAFETY INSTRUCTIONS

WARNING – When using electric products, basic precautions should always be followed, including the following:

- 1) Read all the instructions before using the product.
- 2) Do not use this product near water – for example, near a bathtub, washbowl, kitchen sink, in a wet basement, or near a swimming pool or the like.
- 3) This product should be used only with a cart or stand that is recommended by the manufacturer.
- 4) This product, in combination with an amplifier and headphones or speakers, may be capable of producing sound levels that could cause permanent hearing loss. Do not operate for a long period of time at a high volume level or at a level that is uncomfortable. If you experience any hearing loss or ringing in your ears, you should consult an audiologist.
- 5) The product should be located so that its location does not interfere with its proper ventilation.
- 6) The product should be located away from heat sources such as radiators, heat registers, or other products that produce heat.
- 7) The product should be connected to a power supply only of the type described in the operating instructions or as marked on the product.
- 8) The power-supply cord of the product should be unplugged from the outlet when left unused for a long period of time.
- 9) Care should be taken so that objects do not fall and liquids are not spilled into the enclosure through openings.
- 10) The product should be serviced by qualified personnel when:
 - a) The power-supply cord or the plug has been damaged; or
 - b) Objects have fallen, or liquid has been spilled onto the product; or
 - c) The product has been exposed to rain; or
 - d) The product does not appear to operate normally or exhibits a

marked change in performance; or
e) The product has been dropped or the enclosure damaged.

11) Do not attempt to service the product beyond that described in the user-maintenance instructions. All other servicing should be referred to qualified service personnel.

DANGER: INSTRUCTIONS PERTAINING TO RISK OF FIRE, ELECTRIC SHOCK, OR INJURY TO PERSONS: Do not open the chassis. There are no user serviceable parts inside. Refer all servicing to qualified personnel only.

GROUNDING INSTRUCTIONS:

This product must be grounded. If it should malfunction or breakdown, grounding provides a path of least resistance for electrical current to reduce the risk of electric shock. This product is equipped with a cord having an equipment grounding connector and a grounding plug. The plug must be plugged into an appropriate outlet that is properly installed and grounded in accordance with all local codes and ordinances.

DANGER – Improper connection of the equipment-grounding connector can result in a risk of electric shock. Check with a qualified electrician or serviceman if you are in doubt as to whether the product is properly grounded. Do not modify the plug provided with this product – if it will not fit in the outlet, have a proper outlet installed by a qualified electrician.

SAVE THESE INSTRUCTIONS



Etherwave | Pro *Theremin*

User's Manual

| | |
|--|----|
| <u>Contents</u> | |
| Safety Instructions..... | 1 |
| Introduction..... | 3 |
| What is a Theremin and How is it Played?..... | 4 |
| Getting Started/Setting up Your Etherwave Pro..... | 5 |
| The Components of the Etherwave Pro..... | 9 |
| The Front Panel..... | 10 |
| The Bottom Panel..... | 14 |
| Understanding How a Theremin Works..... | 16 |
| Care of your Etherwave Pro..... | 18 |
| Service/Warranty Information..... | 18 |
| Specifications and Accessories..... | 19 |

Congratulations on purchasing the finest theremin available, the Etherwave Pro. It combines Dr. Robert Moog’s 50 years of theremin expertise with a cutting edge cabinet design. You will find this instrument a rewarding investment - as the “Voice of the Ether” is the most expressive there is. This manual is designed to give you, the Etherwave Pro owner, a thorough understanding of the features of this fine instrument. It does not cover the art of playing or the fascinating history of the instrument. To learn the fine art of playing the theremin, we recommend the DVD entitled “Etherwave Pro: Beginning and Advanced Techniques” featuring Pamela Kurstin. This video presents several lessons on theremin technique in the form of an informal conversation between Ms. Kurstin and Dr. Robert Moog. Moog also produces a DVD which contains “Mastering the Theremin” featuring Lydia Kavina and “Clara Rockmore - World’s Greatest Theremin Virtuosa” - both of which are great additional resources for the budding thereminist. For learning about the history of the instrument, the biography of Leon Theremin by Albert Glinsky, *Ethermusic and Espionage*, (University of Illinois press) is an invaluable resource.

We hope you enjoy your Etherwave Pro theremin and that it brings you many, many hours of enjoyment “pulling music from the air.”

What is a Theremin and How is it Played?

The theremin is a remarkably simple instrument. The playing interface consists of two antennas: the Pitch Antenna, and the Volume Antenna. A single, monophonic tone is produced by the theremin and the proximity of the player's right and left hands to the Pitch and Volume Antennas determines the pitch and volume of the theremin's tone.

The pitch of the theremin's tone is set by the distance of the player's hand from the Pitch Antenna. When properly tuned, the theremin's pitch will rise as the player's hand approaches the antenna, with the full desired pitch range existing in the distance from the player's body to the Pitch Antenna. Because a pitch is determined by the distance from the Pitch Antenna, when the player's hand is at a steady distance from the Pitch Antenna, a recognizable musical note is formed. A challenge in playing theremin lies in learning the relationship of the right hand's distance from the Pitch Antenna to the pitch that is heard, and in learning to maintain a steady distance from the Pitch Antenna to form a pleasant-sounding tone. With no physical contact with the instrument, the player must rely on his or her sense of pitch and muscle memory to produce accurate playing. The right hand typically moves horizontally from the player's body to the Pitch Antenna for the most accurate control of pitch.

The Volume Antenna allows the player to control the dynamics of the theremin's tone. When the left hand is in very close proximity to the Volume Antenna, The tone becomes silent. As the left hand is moved further away from the Volume antenna, the loudness of the tone increases. Articulation is typically performed with rapid movements of the left hand away from the Volume Antenna, and crescendoes and diminuendoes are performed by much slower movements of the left hand away from or nearer to the Volume antenna. The left hand typically moves in and up and down direction above the Volume Antenna, as opposed to the right hand's horizontal movement from the body to the Pitch Antenna.

Playing melodies on the theremin requires practice and patience. The Etherwave Pro DVD featuring Pamela Kurstin will provide you with information about how the instrument is played.

Note for Lefties: For those who have purchased a custom, left-handed version of this instrument, please note this manual was written for the right handed version of the instrument, When reference is made to right or left, those instructions should be reversed.

Getting Started/Setting up your Etherwave Pro

Prepare a workspace with plenty of room for the components of the Etherwave Pro, and a place to connect to a source of AC. You will need to set the Etherwave Pro up in a space with about three feet all the way around the instrument. In addition to the Etherwave Pro, you will need a 1/4" instrument cable and an amplifier, or a set of headphones with a 1/4" plug. Note: **SAVE THE PACKING MATERIALS!** The foam insert in the Etherwave is designed to be re-used in either the Road Case or Gig Bag offered by Moog Music. It is also necessary to keep this, should your Etherwave Pro require shipping for factory service.

- Step 1)** Open the box, and lift the top piece of foam. Check the contents of the box. You should have received:
- a) the Main Cabinet (fig.1)
 - b) Volume Antenna (fig.2)
 - c) Pitch Antenna (fig.3)
 - d) a foam divider under the pitch antenna. Pull it out to reveal
 - e) the Pitch Arm (fig.4)
 - f) the stand (fig.5)
 - g) power cord
 - h) The "Etherwave Pro" DVD and
 - i) this manual.

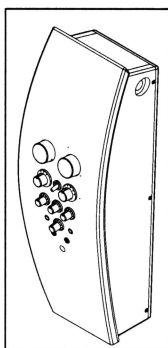

Figure 1 - The Main Cabinet

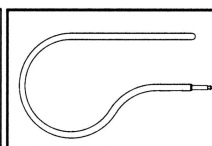

Figure 2 - The Volume Antenna

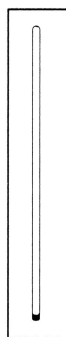

Figure 3 - The Pitch Antenna

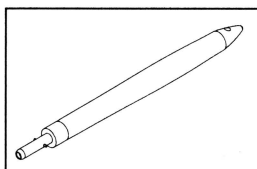

Figure 4 - The Pitch Arm

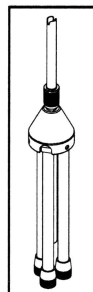

Figure 5 - The Stand

Step 2) Set up the stand

Remove the stand. Loosen the nut on the stand base that binds the outer shaft, raise the outer shaft until it reaches its maximum height. Tighten that nut so the outer shaft is secure. Fold out the legs and place the stand on the floor. Note the slot in the top of the stand, and the stop screw. The stop screw prevents the center shaft from slipping down into the outer shaft, and ensures that the 6 1/2" inches to the top of the stand are available for holding the main cabinet. The slot is used to stabilize the main cabinet as it rests on the stand. The stand's height is adjusted by loosening the collar, and raising the center shaft. The stand is designed so it can be raised up to 10" above its minimum

height, providing a range of 37" to 47" for the distance of the antennas to the floor. NOTE: Do not attempt to raise the stand so there is more than 10" from the stop screw to the collar. This could make the stand unstable.

Step 3) Place the cabinet on the stand.

Remove the Main Cabinet. Look at the bottom of the cabinet and locate the stand receptacle (fig.6). Carefully lift the cabinet so the stand receptacle is aligned with the top of the stand, and slot in the stand is lined up so it goes from the front to the back of the cabinet. Carefully lower the cabinet onto the stand. When the stand is inserted into the receptacle, lower the cabinet until you feel the cabinet resting on the stand. The slot in the stand should engage the retaining pin at the top of the receptacle. (fig.7) Rotate the cabinet slightly if necessary to engage the pin.

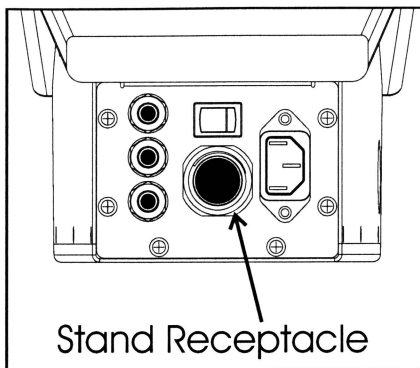

Figure 6 - View of the Bottom Panel and the Stand Receptacle

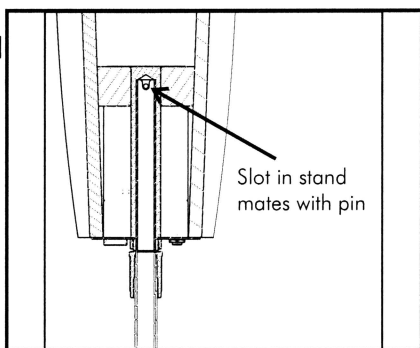

Figure 7 - Cross section diagram of stand mating with pin inside cabinet

Step 4) Install the Pitch Arm.

Remove the Pitch Arm. The Pitch Arm connects the Pitch antenna to the main cabinet. Align the pins on the end of the Pitch Arm with the slots in the Pitch Arm Opening and with the threaded hole on the opposite end rotated toward the front of the main cabinet. (fig.8) Once it is inserted, push slightly and rotate the arm clockwise. You should feel it click in place as the pins are engaged by the spring-loaded connector. The

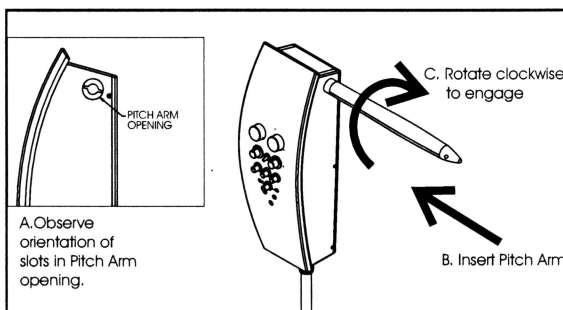

Figure 8 - Installing the Pitch Arm

threaded hole should now be pointing up to receive the Pitch Antenna.

Step 5) Install the Pitch Antenna.

Locate the threaded end of the Pitch Antenna. Carefully screw the pitch antenna into its threaded receptacle on the end of the pitch arm. (fig.9) Do not overtighten. **BE CAREFUL NOT TO CROSS THE THREADS!** Never force the pitch antenna into the threaded hole. If you suspect the connection is becoming crossthreaded, carefully back the antenna out of the hole and start over. An occasional drop of machine oil on the threads will help to preserve them and prevent the threads from wearing out.

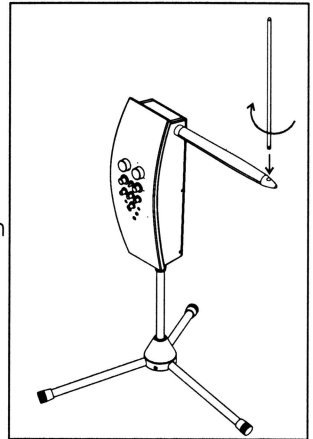

Figure 9 - installing the Pitch Antenna

Step 6) Inserting the Volume Antenna

The Volume Antenna is designed to be inserted so the plug is inserted in the lower of the two holes for the volume antenna, and the bulge in the loop faces forward when it is inserted. (fig.10)

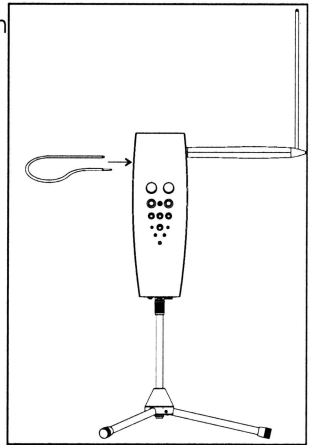

Figure 10 - installing the Volume Antenna

Step 7) Connect to Power

The Power cord has a standard IEC-320-C13 type connector. The receptacle for it is on the bottom of the cabinet. Plug the cord into a source of power. The Etherwave Pro operates on a range of voltages, from 100 to 240 Volts, AC, at 50-60 Hz. Turn the power on with the power switch located next to the power receptacle. The power indicator should light up. Set the Output switch to "Standby".

Step 8) Connect to Amplification

If you are using an amplifier, locate the Audio Out jack on the bottom of the instrument. Insert a 1/4" instrument cable into this jack, and connect the other end of the cable to the appropriate input of your amplifier. The Etherwave Pro features a line-level output, and is best suited for use with an amplifier with a line-level input, such as Moog's TB-15 theremin amplifier. Power up your amplifier, and set the volume to a low level. If you are using headphones, plug them into

the headphone jack on the front panel. Set the Timbre selector to the second (from left) position, and the octave selector to the mid-position.

Step 9) Tuning the Pitch

Set the Volume Tuning control (the control labeled "Volume") to the mid position. Set the Standby switch to "on". Moving your left hand closer to the Volume antenna makes the sound quieter, and moving it away from the antenna makes it louder. For now, leave your left hand at your side so we can focus on the right hand and the control and tuning of the pitch of the theremin's sound. You should hear the theremin's pitch change as you move your right hand closer to the Pitch Antenna - the pitch is controlled by the distance of your body to the Pitch Antenna. Adjust the level of your amplifier to achieve a comfortable listening level if necessary. *Note: If this is your first theremin experience, be prepared for a lot of squeaks and squawks from the instrument as you learn to adjust the Pitch Tuning - It's OK! Nothing bad is happening! Relax and have fun - a certain amount of trial and error is involved as you learn how to tune the theremin.*

Using your right arm to determine the distance, stand so you are arm's length from the Pitch Antenna and your body is in front of the main cabinet. Make all the following pitch adjustments with your left hand. Turn the Pitch Tuning control (the control labeled "Pitch") all the way to the left. You will hear the pitch rise. Now slowly turn the Pitch Tuning control clockwise and listen to the pitch as it goes lower. At a certain point the pitch goes so low that it becomes silent. This is known as "Zero Beat". The Pitch Tuning control sets the distance from the Pitch Antenna to Zero Beat. Slowly turn the Pitch Tuning control counterclockwise and stop when the pitch rises to a very low bass note. Drop your left hand to your side and move your right hand to your right shoulder. Then move it slowly towards the pitch antenna. You will hear the pitch go up. You should have the full range of the theremin in the distance between your body and the pitch antenna.

Step 10) Play!

Now it's time to have some fun - play around with your Etherwave Pro and get used to the feel of moving your right hand from your body to the pitch antenna, and the control of the volume by moving your left hand up and down over the volume antenna. Playing a note on the theremin involves maintaining a steady distance from the pitch antenna. To get the most of your Etherwave Pro, read on, and watch the DVD that was included with your instrument. It will give you lots of tips

on where and how to stand, and the best way of using your hands to control the theremin musically.

The Components of the Etherwave Pro

The following section describes the components of the Etherwave Pro:

Main Cabinet

The Main cabinet houses the electronics of the Etherwave Pro. It is designed to rest on the included stand, and to receive the Pitch Arm assembly and the Volume Antenna. Connections to the power as well as audio and CV outputs are located on the bottom of the cabinet, along with the power switch and stand receptacle. Controls are on the front of the instrument as well as a headphone output and a tuner output.

Theremin Stand

This stand is designed specially to work with the Etherwave Pro. The slotted top mates with a pin inside the instrument's stand receptacle to prevent the instrument from spinning on the stand. The stand folds down quickly for easy transport.

Pitch Arm

The Pitch Arm connects the Pitch Antenna to the Main Cabinet. It is inserted into a springloaded receptacle, and receives the Pitch Antenna at the threaded hole in the end.

Pitch Antenna

The Pitch Antenna is threaded on one end and is screwed into the end of the Pitch Antenna Arm. Be extra careful with the threads of the Pitch Antenna and it will last for a long time. An occasional drop of machine oil is recommended for the maintenance of the threads. Make sure *never* to force it into place or overtighten.

Volume Antenna

The Volume Antenna is a loop with a plug that is inserted into the receptacle on the left side of the main cabinet. The bulge in the loop should face towards the front of the cabinet. Do not allow the end of the antenna to be bent.

Power cord

The power cord is a standard IEC-320-C13 detachable power cordset. Replace it immediately if it is damaged.

Packing Foam

As we stated earlier in the manual - SAVE THE FOAM!! Should you invest in a road case or gig bag to transport the Etherwave Pro, the foam is designed to be reused and protect your investment for many years as you travel with it. It is also required should it become necessary to send your instrument to the factory for repair.

The Front Panel

What follows is an explanation of the functions and usage of the front panel controls:

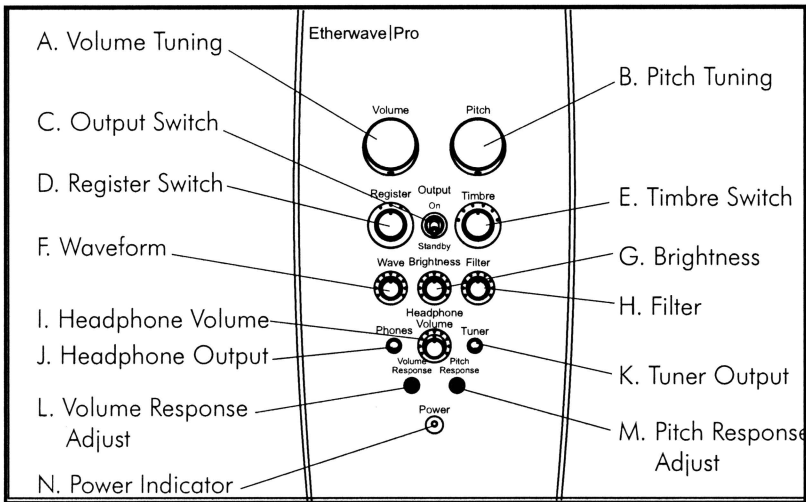

Figure 11 - The Etherwave Pro's Front Panel Controls

Volume

The Volume Tuning control is frequently misunderstood as equivalent to a volume control on an amplifier. This is not the case. The Volume Tuning control is used to set the rate of change in the increase of volume that occurs when the left hand moves away from the Volume Antenna. This rate of change becomes slower as the Volume Tuning control is turned counterclockwise, and becomes faster as it is turned clockwise. Thus, when the Volume Tuning control is all the way to the left, the theremin still produces a tone when the left hand is away from

the antenna. The tone will become quieter, because it is necessary for the player to be further away from the Volume Antenna to produce the loudest tone. As the Volume Tuning control is turned clockwise, the theremin's tone becomes louder, because the amount of distance from the Volume Antenna to produce the loudest tone decreases. To achieve rapid articulations, a fast rate is desired, so smaller motions result in faster changes in loudness.

Pitch

The Pitch Tuning control is used to set the desired distance of zero beat from the Pitch Antenna. By turning the control clockwise, zero beat is moved closer to the antenna. Turning the control counter-clockwise moves zero beat away from the antenna. The ideal setting of the Pitch Tuning control is so that zero beat exists when you are standing in front of the main cabinet with your right hand by your side and are just outside of arm's reach from the Pitch Antenna. This puts the lowest playable note at the distance from your shoulder to the antenna. If zero beat is too close to the Pitch Antenna, then you will hear a "reversed" action on the theremin's pitch - that is as you move towards the antenna, the pitch goes down - eventually it goes to zero beat and then rises again. This is normal. It is not usually used for playing the theremin, but can be used for creating special sound effects. Because the theremin is very sensitive to its environment, it is likely that the Pitch Tuning will require adjustment each time you turn on your Etherwave Pro. It is also normal to readjust the Pitch Tuning after the theremin has been on for a few minutes. As the Etherwave Pro's circuits warm up, the response of the Pitch Antenna will change slightly.

Output Switch

The Output Switch is used to mute the audio output of the Etherwave Pro when the instrument is not being played, without the need for turning the instrument off. In the "On" Position, the Etherwave's signal is sent to the output, In the "Standby" position it is muted.

Register

The Register control is a three-position rotary switch used to select the overall range of the theremin. The left position has a range that enables the thereminist to play two octaves above middle C. The center position shifts the pitch of the highest note (the note heard when touching the Pitch Antenna) up one octave, enabling the thereminist to play three octaves above middle C. The right position shifts this tone

up one more octave as well, allowing the thereminist to play up to four octaves above middle C. The overall playable ranges are then, 5, 6, and 7 Octaves. For playing basslines and deep melodies the left-most position should be used. For playing very high-pitched melodies, the right-most position should be used. The middle position is excellent for playing in the middle of the musical range.

Timbre

The Timbre control is a six-position rotary switch used to select the three front panel timbre controls, or one of the five pre-programmed theremin timbres. When the Timbre control is in the full counterclockwise position (the first position), the front panel tone controls are engaged, thus the Etherwave Pro's timbre is set by the positions of the Waveform, Brightness, and Filter controls. These controls have wide ranges, and each contributes greatly to the overall timbre, giving the player a great number of possibilities in choosing a "voice" for the theremin.

The second to sixth positions of the Timbre switch are pre-programmed timbres, fixed in the Etherwave Pro's hardware. The Waveform, Brightness, and Filter controls are disabled when the timbre switch is in one of these positions. These timbres are classic theremin tones, carefully crafted to emulate Leon Theremin's original designs, as well as some tones that the theremin has come to be known for over the years. The following is a list of these timbres:

- 2) "Whistling" - very simple sine-like waveform
- 3) "Mellow Theremin" - mellow-sounding waveform
- 4) "Singing" - the classic singing theremin tone
- 5) "Basic Theremin" - A classic theremin tone.
- 6) "Bright String" - very bright in the bass range, like a cello.

Wave

The Waveform control is active when the Timbre selector is in the first position. It is used to set the overall harmonic structure of the waveform produced by the theremin. To hear the effect of the Waveform control, turn the Brightness and Filter controls up, play a low note and rotate the Waveform control from one extreme to the other. When the control is in the full counterclockwise position, the waveform is rich in odd harmonics, producing a more hollow, full timbre. When the Waveform control is fully clockwise, more harmonics are added, and the sound of the theremin becomes bright and reedy.

Brightness

The Brightness control is active when the Timbre selector is in the first position. It is part of the wave-shaping circuit and strengthens harmonics as it is rotated clockwise. To hear its effect, Turn the Filter control all the way up, play a low note, and rotate the Brightness control from full counterclockwise to clockwise. In the counterclockwise position, the theremin's sound will be mellow, even muted. In the full clockwise position, the theremin's tone is buzzy and bright.

Filter

The Filter control is active when the Timbre selector is in the first position. The Filter control sets the cutoff frequency of a lowpass filter that is used to further shape the timbre of the theremin's tone. When the Filter control is all the way clockwise, all the harmonics of the theremin's tone pass through, making for a very bright timbre. As the control is turned down, less of the theremin's harmonics are allowed to pass, making the timbre much more muted. In addition to the Filter control having an effect on the filter, the pitch affects it as well. This feature can help create a more natural sound throughout the range of the theremin, as the harmonics of the theremin change with pitch just as they do in an acoustic instrument.

Headphone Volume

Headphone volume is the control that sets the volume of the theremin's signal through the 1/4" Headphone output on the front panel.

Phones

The Phones output is a 1/4" headphone socket on the front panel of the Etherwave Pro. The headphone output has a unique feature. When the left hand is very close to the Volume Antenna, a small amount of the "pre-volume" theremin signal is sent to the headphones, allowing the player to hear the Etherwave Pro's pitch before sending the note to the audio output.

Tuner

The Tuner output is a 1/4" output of the theremin's tone before it is controlled by the volume antenna. This output, when used in conjunction with an electronic tuner, can be used to preview the pitch of the theremin before a note is started with the volume antenna.

Pitch Response

The Pitch Response adjustment sets the spacing of bass intervals, as well as adjusts the width of zero beat. Pitch Response has a subtle effect on timbre as well. When the Pitch Response adjustment is turned counterclockwise, the distance between the bass intervals is increased, zero beat occurs in a more narrow distance, and the timbre becomes more sinusoidal. When the control is turned clockwise, the bass intervals become closer together, zero beat is wider, and the waveform becomes more asymmetrical. The player can tailor this response to what feels right as far as their body size and movements. The control itself is recessed beneath the panel and is adjusted with a small flathead screwdriver.

Volume Response

The Volume Response adjustment sets the distance from the Volume Antenna at which the theremin's notes begin to sound. When the control is fully counterclockwise, the start point is very close to the Volume Antenna, which helps in achieving quick, staccato playing. The adjustment, when turned clockwise, moves the start point away from the antenna. This control also affects the headphone output. When the start point is far enough away from the antenna that the player's hand can approach a bit more, this fades in a pre-volume theremin signal to the headphones. The control itself is recessed beneath the panel and is adjusted with a small flathead screwdriver.

The Bottom Panel

The Bottom Panel of the Etherwave Pro houses audio, control voltage (CV), and power connections. The following is a description of their functions:

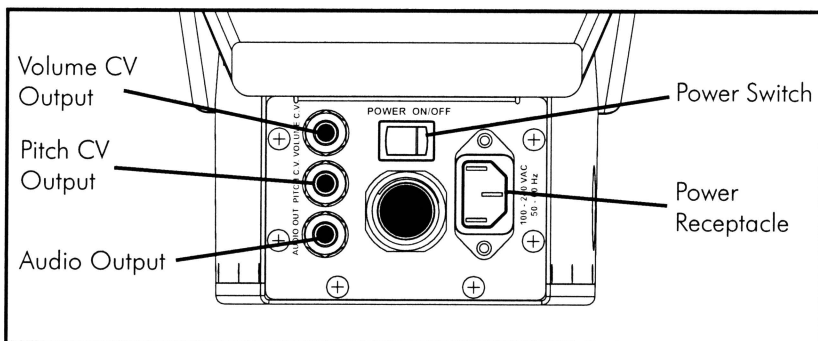

Figure 12 - The Etherwave Pro's Bottom Panel

Power

The power receptacle is a standard IEC-320-C13 type connector. The Etherwave Pro can be powered from any source of 100-240 VAC, 50-60 Hz.

Audio Out

The Audio output is a 1/4" jack that delivers the Etherwave Pro's signal. It is an unbalanced, line-level connection.

Pitch and Volume CV (Control Voltage)

The Pitch and Volume CV outputs are 1/4" jacks that carry voltages that vary with the proximity of the player's hands to the Pitch Antenna and Volume Antenna. These can be used to connect to voltage-controlled electronic musical instruments, such as the Minimoog Voyager® analog synthesizer, or moogerfooger® analog effects.

The Pitch CV is a voltage that changes at a rate of 1 volt/octave with the pitch of the Etherwave Pro, increasing as the pitch rises. Middle C is equal to zero volts.

The Volume CV is a voltage that is 0 V when the left hand is very close to the Volume Antenna, and +5 Volts when the maximum volume of the theremin is achieved.

Connecting to CV-compatible equipment.

Moog Music makes several CV-compatible electronic musical devices, including the Minimoog Voyager analog synthesizer, and the Moogerfooger Analog Effects. The Etherwave Pro can be used to control various parameters on these devices for creating special effects, or for creating a unique theremin sound.

Connecting the Pitch and Volume CV outputs of the Etherwave Pro to the Pitch and Volume CV inputs of the Minimoog Voyager is a good example. This can control the pitch and volume of the sound of the Minimoog Voyager.

Using the Etherwave Pro with effects can be very interesting as well. For instance, an Etherwave Pro that has its audio out connected to the audio input of a MF-102 Ring Modulator, and its Pitch and Volume CV outputs connected to the Frequency and Mix control inputs of the MF-102 can create some very unusual effects. When the effect is active, and the Frequency and Mix controls are turned all the way down, the pitch will control the Ring Modulator's carrier oscillator frequency, and the volume will control the dry/wet balance. With this setup, when the theremin is loud, you will hear just the effect, and when it's quiet, the

unprocessed sound will be more prominent.

For more information about the use of CVs, we recommend reading the CP-251 Control Processor User's Manual, available online at www.moogmusic.com.

Understanding How a Theremin Works

Understanding more about the technical workings of the theremin can aid in understanding what is happening when you are playing it. The playing interface consists of two antennas: the Pitch Antenna, and the Volume Antenna. A single, monophonic tone is produced by the theremin and the proximity of the player's right and left hands to the Pitch and Volume antennas determines the pitch and volume of the theremin's tone. The Figure 13 is a block diagram of a simple theremin.

The theremin tone itself is produced by a "Beat-Frequency Oscillator", or BFO. A BFO consists of two vibrating circuits, or oscillators. When the two oscillators are at different frequencies a "Difference Frequency" is produced. This phenomenon can be observed by playing two adjacent notes on a piano or keyboard near Middle C. In addition to the two notes that are heard, a third vibration is produced - also known

as "Beating". This is the difference frequency. The two oscillators in the theremin's BFO are vibrating much faster than what can be heard, one is at a fixed frequency, and one is varied by the proximity of the player's hand to the Pitch Antenna. The difference in the frequencies of the two oscillators produce the theremin tone you hear. When they are at the same frequency, they produce no sound - this is "Zero Beat". This method of tone production is quite sensitive to movements in the space around it. That is what makes the theremin very expressive and

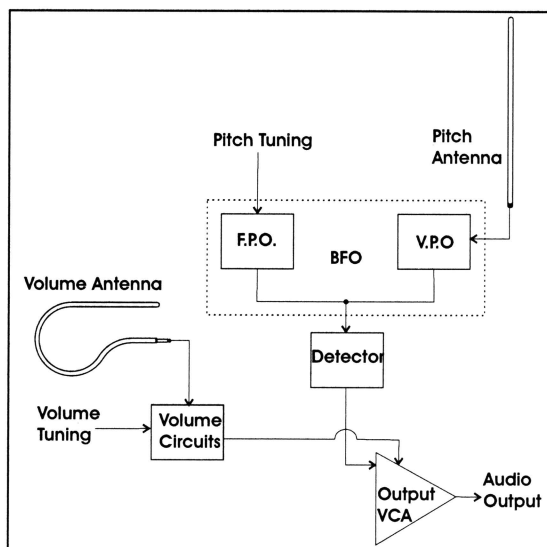

Figure 13 - Block Diagram of Simple Theremin

responsive, but also challenging. Always set your theremin up so it has its own space, as any movement close to the instrument affects the pitch of the theremin's tone.

The tone of the theremin would be quite monotonous if it were always at the same volume. The Volume Antenna allows the player to control the loudness of the theremin's tone. When the left hand is very close to the Volume Antenna, The tone becomes silent. As the left hand is moved further away from the Volume Antenna, the loudness of the tone increases. The Volume Tuning sets the rate of change in loudness as the left hand is pulled away from the Volume Antenna. A faster rate allows for more staccato playing, while a slower rate of makes for more easily controllable crescendos and diminuendos.

The Etherwave Pro uses the basic principles of the theremin, but features a number of refinements in the circuitry that create its rich sound and fine playing response. Figure 14 is a block diagram illustrating the functions of the circuitry.

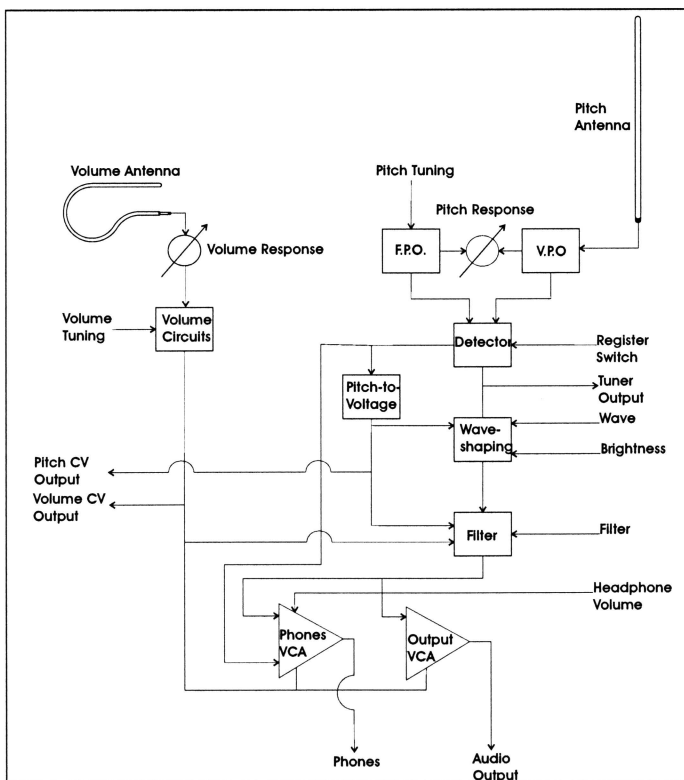

Figure 14 - Block Diagram of Etherwave Pro

Care of Your Etherwave Pro

Your Etherwave Pro is designed to last for a lifetime of musical service. In order to get the most out of your instrument it is recommended that you treat the instrument with the care that it deserves.

Cleaning the Etherwave

The theremin's finish is a lacquer-based finish, and cleaning requires a very soft cloth and a non-abrasive, non-oily cleaner like a fine guitar polish. We don't recommend the use of waxy polishes. Never use abrasives or solvents to clean the finish.

Handling

The Etherwave theremin is built quite sturdily, but should be handled with care to preserve the beauty of the instrument. Take special care with the edges of the instrument which may be vulnerable to "dings" if not carefully handled. Be careful when plugging into the phones or tuner outputs, or when adjusting the Pitch or Volume Response with a screwdriver.

Operating Conditions

The Etherwave theremin should not be operated outside in adverse weather conditions. It should operate well in most indoor conditions. Under no conditions should you block the holes on the back panel - these are designed for ventilation and if blocked could damage the internal circuitry.

Storage

The Etherwave Pro should not be stored in extreme hot or cold conditions. Think about how you like to store yourself and treat the Etherwave Pro accordingly. We recommend storing it in the original packaging, or in the road case if it is to be stored for a long period of time, as that will help to protect the cabinet from accidental damage.

Service/Warranty Info

Your Etherwave Pro has a one year limited warranty. This warranty covers parts and labor, but excludes normal wear and tear, changes in specifications, and catastrophic occurrences. You should refer to the warranty registration for the exact terms and conditions. Should you

develop problems with your Etherwave Pro please contact Moog Music tech support (by email techsupport@moogmusic.com) and describe your problem in as much detail as possible. You may also contact tech support at 828-251-0090, or toll free in the US 800-948-1990. All instruments returning to the factory must be accompanied by a Return of Materials Authorization Number (RMA#) assigned by an authorized Moog Music agent or employee. Instruments returned without proper authorization will be refused.

Specifications and Accessories

SPECIFICATIONS

*** PITCH ANTENNA/PITCH CONTROL**

The Pitch Antenna is a vertically mounted antenna that is 18" long, made of nickel-plated 3/8" brass tube. Its end is threaded, and screws into the Pitch Arm that makes the connection from the Pitch Antenna to the theremin cabinet. The Pitch Arm is removable from the main theremin cabinet for easy transport.

The pitch of the theremin's tone is determined by the distance from the Pitch Antenna of the player's right hand. Pitch control of the theremin's tone is designed so when the Pitch Tuning control is properly adjusted, the pitch increases from minimum (0 Hz or Zero Beat) to Maximum (6 KHz) as the distance of the right hand from the Pitch Antenna decreases from approximately 30 inches to 0 inches.

*** VOLUME ANTENNA/VOLUME CONTROL**

The Volume Antenna is a horizontally mounted looped antenna that is 10" long, made of nickel-plated 3/8" brass tube, fitted with a plug that easily attach/detach to the socket on the left side of the cabinet.

The Volume of the theremin's tone is determined by the distance from the Volume Antenna of the player's left hand. Volume control of the theremin's tone is designed so the instrument is silent when a player's hand is close to the Volume Antenna and increases as the hand is moved away from the antenna.

Front Panel Features:

- * **PITCH** rotary control, for adjusting the response of the Pitch Antenna. Sets the distance from the Pitch Antenna of the lowest note, zero beat.
- * **VOLUME** rotary control, for adjusting the response of the Volume Antenna. Sets the rate of volume increase as the player's hand moves away from the antenna.
- * **OUTPUT** toggle switch mutes the audio output when in Standby, passes the theremin's tone to the output when On.
- * **REGISTER** rotary switch selects one of three octave ranges, with maximum pitch of 2,3, or 4 octaves above middle C.
- * **TIMBRE** rotary switch selects the front panel timbre controls, or one of five preset classic theremin timbres.
- * **WAVE** rotary control, for adjusting the waveform of the audio output.
- * **BRIGHTNESS** rotary control, for adjusting the brightness of the audio output.
- * **FILTER** rotary control, for adjusting the change in timbre that occurs as the pitch is

increased.

- * PHONES Output 1/4" headphone jack for monitoring with headphones. Output Impedance 600 Ω
- * HEADPHONE VOLUME rotary control adjusts the level of the headphone output.
- * TUNER OUT 1/4" jack provides pre-volume antenna signal for previewing pitch with a tuner.
- * VOLUME RESPONSE Adjustment sets distance from Volume Antenna of zero volume.
- * PITCH RESPONSE Adjustment sets spacing of bass intervals, and width of zero beat.

Bottom Panel Features:

- * POWER: 90-264 Volts AC; 45 Watts
- * UNBALANCED AUDIO OUTPUT: 0 dBm Nominal Output Level; 5000 Ω Output Impedance.
- * PITCH CONTROL VOLTAGE OUTPUT: 1 Volt/Octave; 0 Volts Corresponds to Middle C; Range is -3 V to +4 V.
- * VOLUME CONTROL VOLTAGE OUTPUT: 0 V to +5 V
- * CABINET DIMENSIONS: 18" Wide x 15 1/2" Deep x 15" High.
- * TOTAL HEIGHT w/ STAND: 38" - 48" (Adjustable, Without Pitch Antenna).
- * WEIGHT: 14 LBS.

ACCESSORIES

- * ROAD CASE - Rugged molded road case built to ATA specs for serious travel. Comes with telescoping handles and casters. Uses packing material shipped with Etherwave Pro (pn: EW-RC-M)
- * GIG BAG - Durable nylon gig bag with handle, strap and pouch for cables for travelling around town. Uses packing material shipped with Etherwave Pro. (pn: EW-Gig-02)
- * TB-15 THEREMIN AMPLIFIER - 30 Watt Amplifier Combo with 2 inputs and 3-band EQ for practice or small venue performance. For use with 110 Volts AC only (TB-15)

*****Specifications subject to change without notice*****

© 2004 Moog Music Inc., All Rights Reserved

Moog Music Inc. 554C Riverside Dr. Asheville NC 28801 USA
ph:828-251-0090 toll-free:800-948-1990
email: info@moogmusic.com <http://www.moogmusic.com>

Moog Music Inc. 554-C Riverside Drive, Asheville, NC 28801

Ph. > 1.800.948.1990 Web > www.moogmusic.com

Copyright © 2004 Moog Music Inc. USA Made in USA.

Registered trademark of Moog Music Inc. USA.

Addendum/Errata for Etherwave Pro User's Manual

The following additions or changes to the text of the User's Manual should be noted:

- **Stop Screw/Adjusting height of stand (p.5)**

The Stop screw has been removed from the design of the stand. The following is a more detailed step-by-step procedure for setting the stand up at the correct height to replace Step 2 in the manual.

1) Loosen the thumbscrew that holds the outer shaft of the stand. Raise the outer shaft all the way. Tighten the thumbscrew firmly.

2) Fold the legs out.

3) Determine how high to raise the inner shaft of the stand. To do this, measure the distance from your hand to your ground, when your forearm and hand are extended and perpendicular to your upper arm and body. This distance is a good measurement of the distance that you will want the Volume Antenna from the floor. The Etherwave Pro stand can be set so this distance is from 38" to 48". Raising the inner shaft 1" places the volume antenna at a distance of 38" from the floor. Raising the inner shaft 11" places the volume antenna at a distance of 48" from the floor. These are the minimum and maximum heights for raising the inner shaft of the stand for safe usage.

4) Loosen the collar holding the inner shaft. Raise the inner shaft by the distance, from one to eleven inches as determined by the previous step, align the slot in the top to be perpendicular to one of the legs, and tighten the collar very firmly. You may wish to mark the height of the inner shaft with a permanent paint marker for a quick visual reference.

- **Warning! Align Pitch Arm with leg of stand (p.6)**

In the previous step, the slot at the top of the stand should have been aligned to be perpendicular to one of the legs of the stand. The cabinet should be oriented so when the pitch arm is installed, it is directly over that leg of the stand (similar to the illustration in Figure 9). This adds to the stability of the design and can help prevent accidental toppling of the Etherwave Pro.

- **Change to Headphone Output (p.13)**

Under "Phones", the feature that fades in the pre-volume signal as the left hand is very close to the Volume Antenna has been removed from the Etherwave Pro.